



Class 12 physics

Important Questions

Chapter 3

Current Electricit

1 Mark Questions

1. If the temperature of a good conductor decreases, how does the relaxation time of electrons in the conductor change?

Ans. We know $\rho = \frac{m}{ne^2 \tau}$

When temperature decreases, collision decreases and thus relaxation time increases which in turn decreases the resistivity.

2. If potential difference V applied across a conductor is increased to 2V, how will the drift velocity of the electron change?

Ans. $Vd = \frac{e E \tau}{m}$

$Vd = \frac{e V \tau}{\ell m}$

∴ Double the P.D means drift velocity gets doubled.

3. What is the value of current I at O in the adjoining circuit?

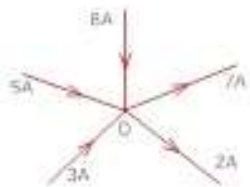

Ans. $i = 5 + 3 - 2 - 7 + 8$



$$i = 16 - 9$$

$$i = 7A$$

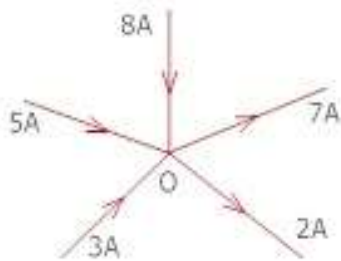

4. State one condition for maximum current to be drawn from the cell ?

Ans. Since $I = \frac{E}{R + r}$ for maximum current, internal resistance should be Zero.

5. Resistivities of copper, silver and manganin are $1.7 \times 10^{-8} m$, $1.0 \times 10^{-8} m$ and $44 \times 10^{-8} m$. respectively which of these is the best conductor ?

Ans. For a particular length and area of cross-section, The resistance is directly proportionate to, specific resistance .

∴ silver is the best conductor because its specific resistance is less.

6. Draw the graph showing the variation of conductivity with temperature for a metallic conductor?

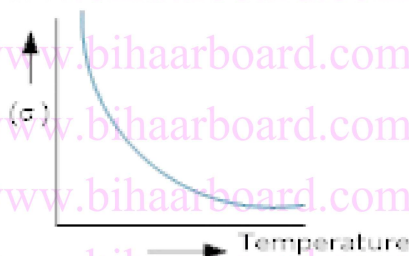

Ans. The conductivity decreases with the increase in temperature.

7. If a wire is stretched to double of its length. What will be its new resistivity?



Ans. No change in its resistivity because resistivity depends only on the nature of the material.

8. Name any one material having a small value of temperature coefficient of resistance.

Write one use of this material?

Ans. Nichrome, an alloy has small value of temperature coefficient of resistance. It is used for making standard resistance coil.

9. Two wires A and B are of the same metal and of same length have their areas of cross section in the ratio 2:1 if the same potential difference is applied across each wire in turn, what will be the ratio of current flowing in A & B?

Ans. Since $R = \frac{l}{A}$

If area are in the ratio 2:1 resistance will be in the ratio 1:2.

$$\text{And } I = \frac{V}{R} \Rightarrow I = \frac{1}{R}$$

\therefore current will be in the ratio 2:1



2 Mark Questions

1. Two electric bulbs A and B are marked 220V, 40 w and 220V, 60 W respectively. Which one has a higher resistance?

Ans. We know $R = \frac{V^2}{P}$

For Bulb A, $R_1 = \frac{(220)^2}{40} = 1210\Omega$

For Bulb B $R_2 = \frac{(220)^2}{60} = 806.67\Omega$

Bulb A has higher resistance because its power is less.

2. A Carbon resistor has three strips of red colour and a gold strip. What is the value of resistor? What is its tolerance?

Ans. R R R Gold

$(22 \times 10^2) \pm 5\%$ Value of the Resistor = 2200Ω

Tolerance = $\pm 5\%$

3. Determine the voltage drop across the resistor R_1 in the circuit given below with $E = 60V$, $R_1 = 18\Omega$, $R_2 = 10\Omega$, $R_3 = 5\Omega$ and $R_4 = 10\Omega$?

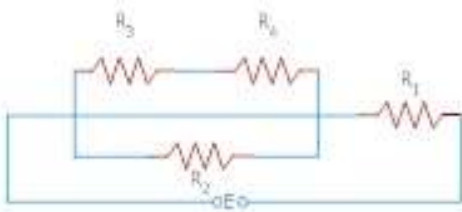



Ans. R_3 & R_4 are in series

$$= R^1 = 5 + 10 = 15 \Omega$$

Now R_1 and R_2 are parallel

$$\therefore \frac{1}{R''} = \frac{1}{R^1} + \frac{1}{R_2}$$

$$\frac{1}{R''} = \frac{1}{15} + \frac{1}{10} = \frac{4+6}{60} = \frac{10}{60}$$

$$R'' = \frac{60}{10} = 6 \Omega$$

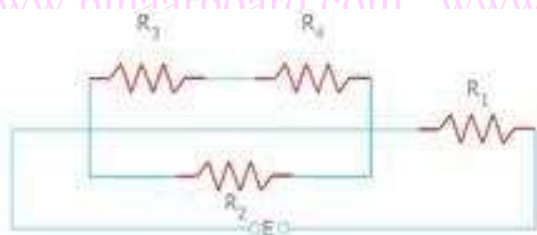

Now R_1 and R'' are series

$$R_{net} = R'' + R_1$$

$$\Rightarrow R_{net} = 6 + 18 = 24 \Omega$$

$$I = \frac{V}{R} = \frac{60}{24} \text{ Ampere}$$

Now voltage drop across

$$R_1 = IR_1 = \frac{60}{24} \times 18$$

$$V = 45 \text{ Volts}$$



4. Two heated wires of same dimensions are first connected in series and then it's parallel to a source of supply. What will be the ratio of heat produced in the two cases?

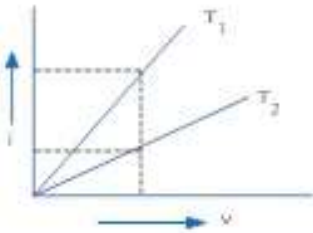

Ans. $H = I^2 R t$ ($\because I = \frac{V}{R}$) Let Resistance of each wire = R

$$H = \frac{V^2}{R^2} \times R \times t$$

$$H = \frac{V^2}{R} t$$

$$\Rightarrow H \propto \frac{1}{R}$$

$$\frac{H_{series}}{H_{parallel}} = \frac{R_{parallel}}{R_{series}}$$

$$= \frac{\left(\frac{1}{R} + \frac{1}{R}\right)^{-\frac{1}{R}}}{\frac{R}{2}} = \frac{R}{2R \times 2} = \frac{1}{4}$$

5. V.I graph for a metallic wire at two different temperatures T_1 and T_2 is shown in figure. Which of these two temperatures is higher and why?

Ans. Slope $\frac{i}{V} = \frac{1}{R}$

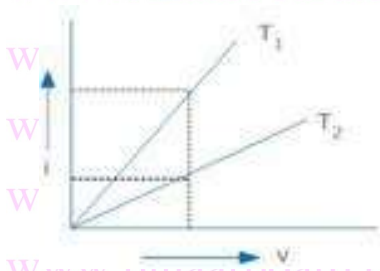

= Smaller the slope larger is the resistance and since resistance increases with the increases in temperature for metals. Slope is small for T_2

T_2 temperature is higher

6.A set of n-identical resistors, each of resistance R ohm when connected in series have an effective resistance of X ohm and when the resistors are connected in parallel the effective resistance is Y ohm. Find the relation between R, X and Y ?

Ans. n – resistors connected in series

$$X = nR \text{ ----1)}$$

n – Resistors connected in parallel

$$Y = \frac{R}{n} \text{ ----2)}$$

Multiply eg. (1) & (2)

$$XY = nR \times \frac{R}{n}$$

$$XY = R^2 \quad \boxed{R = \sqrt{XY}}$$

7. Show the resistance of a conductor is given by $R = \frac{ml}{ne^2 \tau A}$

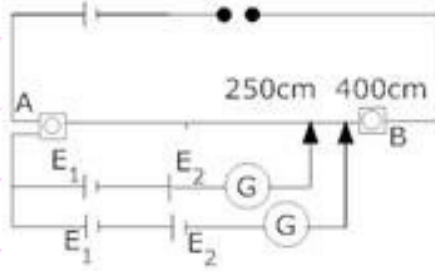

Ans. For a conductor of length l and area A if (E_1) electric field is applied, Then the drift

velocity of electrons is given by

$$vd = \frac{eE}{m} \tau$$

Since $I = neAv_d$

$$I = neA \left(\frac{eE}{m} \tau \right)$$

$$I = neA \left(\frac{eV}{ml} \tau \right) (\because E = v/l)$$

$$\frac{V}{I} = \frac{ml}{ne^2 A \tau}$$

$$R = \frac{m}{ne^2 \tau} \left(\frac{l}{A} \right) (\because V/I = R)$$

$$\text{or } R = \frac{ml}{ne^2 \tau A}$$

8. Figure shows a piece of pure semiconductor S in series with a variable resistor R and a source of constant voltage V . Would you increase and decrease the value of R to keep the reading of ammeter (A) constant, when semiconductor S is heated? Give reasons.

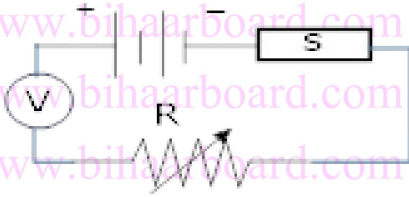

Ans. Resistance of a semi conductor decreases on increasing the temperature, so in order to increase the temperature, s is heated and in order to maintain the ammeter current constant total resistance in the above circuit should remain unchanged, hence value of r has to be increased.

9. Why is constantan or manganin used for making standard resistors?

Ans. The alloys such as constantan or manganin are used for making standard resistors because their resistivities are high and has low temperature coefficient of resistance.

10. What are ohmic and non-ohmic resistors? Give one example of each?

Ans. A resistor which obey ohm's law are called ohmic resistors for eg -> metals

A resistor which do not obey ohm's law are called non-ohmic resistors .eg -> semiconductor diode , transistor etc.

11. The storage battery of a car has an emf of 12 V. If the internal resistance of the battery is 0.4Ω , what is the maximum current that can be drawn from the battery?

Ans. Emf of the battery, $E = 12 \text{ V}$

Internal resistance of the battery, $r = 0.4 \Omega$

Maximum current drawn from the battery can be calculated as:

The maximum current drawn from the given battery is 30 A.

12. In a potentiometer arrangement, a cell of emf 1.25 V gives a balance point at 35.0 cm length of the wire. If the cell is replaced by another cell and the balance point shifts to



63.0 cm, what is the emf of the second cell?

Ans. Emf of the cell, $E_1 = 1.25V$

Balance point of the potentiometer, $l_1 = 35cm$

The cell is replaced by another cell of emf E_2 .

New balance point of the potentiometer, $l_2 = 63cm$

The balance condition is given by the relation,

$$\frac{E_1}{E_2} = \frac{l_1}{l_2}$$

$$E_2 = E_1 \times \frac{l_2}{l_1}$$

$$= 1.25 \times \frac{63}{35} = 2.25V$$

Therefore, emf of the second cell is 2.25 V.

13. What conclusion can you draw from the following observations on a resistor made of alloy manganin?

CURRENT	VOLTAGE	CURRENT	VOLTAGE
0.2	3.94	3	59.2
0.4	7.87	4	78.8
0.6	11.8	5	98.6
0.8	15.7	6	118.5
1.0	19.7	7	138.2
2.0	39.7	8	158.0

Ans. It can be inferred from the given table that the ratio of voltage with current is a constant, which is equal to 19.7. Hence, manganin is an ohmic conductor i.e., the alloy obeys Ohm's law. According to Ohm's law, the ratio of voltage with current is the resistance of the conductor. Hence, the resistance of manganin is 19.7Ω .



3 Mark Questions

1. What happens to the resistance of the wire when its length is increased to twice its original length?

Ans. $R = \rho \frac{\ell}{A} = \rho \left(\frac{\ell}{\pi r^2} \right)$

Now $\ell^1 = 2\ell$ and radius becomes r^1

Since volume of the wire remains the same

$$\pi r^2 \ell = \pi r'^2 \ell 1 = \pi r'^2 2\ell$$

$$r'^2 = r^2 / 2$$

∴ New Resistance

$$R' = \rho \left(\frac{\ell'}{\pi r'^2} \right)$$

$$R' = \rho \left(\frac{2\ell}{\pi r^2 / 2} \right)$$

$$R' = 4\rho \left(\frac{\ell}{\pi r^2} \right)$$

∴ New Resistance becomes four times.

2. Mark the direction of current in the circuit as per kirchoff's first rule. What is the value of main current in the shown network?





Ans. R_2 and R_3 are in series

$$R = 3+3=6\Omega$$

R and R_1 are in parallel

$$\frac{1}{R_{net}} = \frac{1}{R} + \frac{1}{R}$$

$$\frac{1}{R_{net}} = \frac{1}{6} + \frac{1}{3} = \frac{3+6}{18}$$

$$R_{net} = \frac{18}{9} = 2\Omega$$

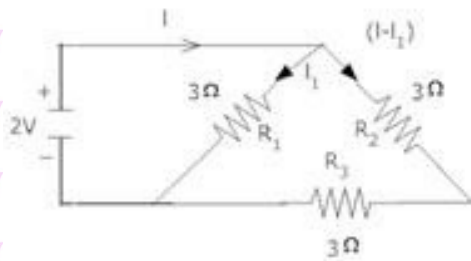

Net Current

$$I = \frac{V}{R}$$

$$I = \frac{2}{2} = 1A$$

3.(a) Why do we prefer potentiometer to measure the emf of cell than a voltmeter?

(b) With suitable circuit diagram, show how emfs of 2 cells can be compared using a



potentiometer?

Ans. (a) Since potentiometer is based on null method i.e. it draws no current from the cell therefore potentiometer is preferred to measure the emf of a cell than a voltmeter because emf of a cell is equal to terminal potential difference when no current flows from the cell.

(b) Potentiometer works on the principle that when a constant current flows through the wire of Uniform area of cross- section then

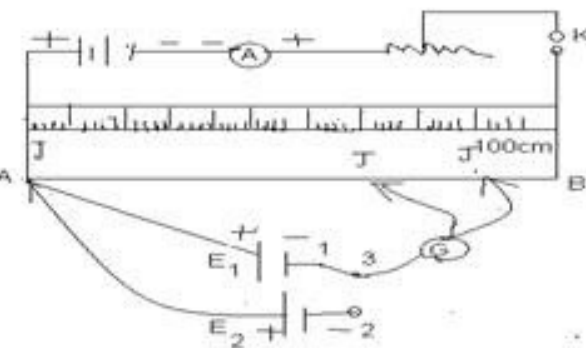

(Condition – close the switch and 3 such that E_1 comes in the circuit)

P.D. across AJ is $V_{AJ} \propto l_1$

Since no current flows between E_1 and V_{AJ}

$$= V_{AJ} = El$$

$$= E_1 \propto l_1 \Rightarrow E_1 = Kl_1 \text{ ---(1)}$$

Close the switch 2 and 3 , cell E_2 comes in the circuit and balance point is obtained of J_1

= Since no current flows because A and J_1 are at same potential then $V_{AJ_1} = E_2$

$$= V_{AJ_1} = E_2 = Kl_1 \text{ ---(2)}$$



Comparing eq. (1) and (2)

$$\frac{E_1}{E_2} = \frac{Kl_1}{Kl_2}$$

$$\frac{E_1}{E_2} = \frac{l_1}{l_2}$$

4. Potential difference V is applied across the ends of copper wire of length (l) and diameter D. What is the effect on drift velocity of electrons if

(1) V is doubled

(2) l is doubled

(3) D is doubled

Ans.

(1) Since V_d

$$\begin{aligned} &= V_d = \frac{I}{neA} = \frac{V}{R(neA)} \\ &= \frac{V}{\left(\frac{\rho l}{A}\right)(neA)} = \frac{V}{\rho n e^2 l} \end{aligned}$$

V is doubled, drift velocity gets doubled.

(2) If l is doubled, drift velocity gets halved.

(3) Since V of is independent of D, drift velocity remains unchanged.

5. What is drift velocity? Derive expression for drift velocity of electrons in a good conductor in terms of relaxation time of electrons?

Ans. It is defined as the average velocity with which free electrons get drifted in a direction opposite to that of electric field



If m is the mass of the electron and e be the charge of electron

Then on application of the electric field E , acceleration acquired by the electron is

$$a = \frac{eE}{m}$$

first eq of motion $v = u + a t$

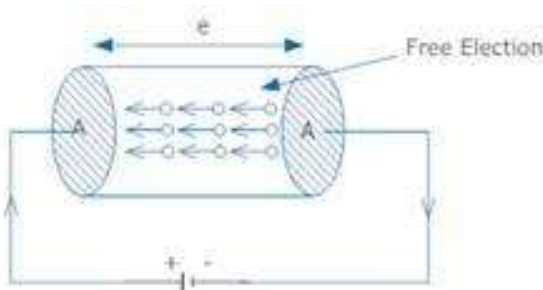

since average initial velocity

$$u = 0 \quad v = v \quad d$$

$$t = \tau$$

(relaxation time)

$$\Rightarrow vd = a \tau$$

$$vd = \frac{e E \tau}{m}$$

where e is the charge on electron

E is the electric field intensity

τ is the relaxation time

m is the mass of electron.

6. The potentiometer circuit shown, the balance (null) point is at X. State with reason,

where the balance point will be shifted when

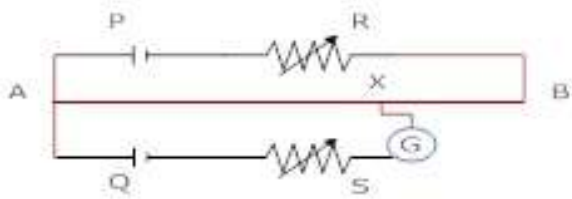

(1) Resistance R is increased, keeping all parameters unchanged.

(2) Resistance S is increased, keeping R constant.

(3) Cell P is replaced by another cell whose emf is lower than that of cell Q.

Ans. (a) When resistance R is increased, the current through potentiometer wire AB will decrease, hence potential difference across A will decrease, so balance point shifts towards B.

(b) When resistance S is increased terminal potential difference of the battery will decrease, so balance point will be obtained at smaller length and hence shifts towards A.

(c) When cell P is replaced by another cell whose emf is lower than that of cell Q, the P.D. across AB will be less than that of emfQ so balance point will not be obtained.

7. (a) Using the principle of wheat stone bridge describe the method to determine the specific resistance of a wire in the laboratory. Draw the circuit diagram and write the formula used ?

In a whetstone bridge experiment, a student by mistake, connects key (k) in place of galvanometer and galvanometer (G) in place of Key (K). What will be the change in the deflection of the bridge.

Ans. (a) Close the Key (k) and jockey is moved along the wire till a certain point B is reached where galvanometer shows no deflection. Then the bridge is said to be balanced.

If Rcm is the resistance per can length of the wire then.

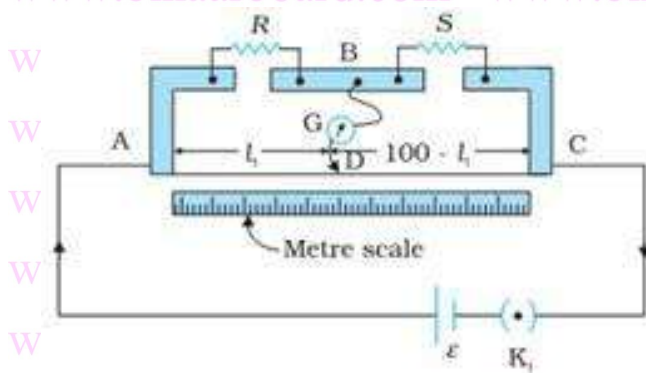

$$\frac{R}{X} = \frac{l R_{cm}}{(100-l) R_{cm}}$$

$$X = \frac{R(100-l)}{l}$$

Since $P = \frac{XA}{\ell^1}$ Where ℓ^1 is the length of the wire.

$$P = \frac{R(100-l)A}{\ell(\ell)}$$

(b) When the bridge is balanced, there will be no current in key, therefore constant current flows through the galvanometer and hence no change in deflection on pressing the key.

8. Two primary cells of emf's E_1 and E_2 are connected to the potentiometer wire AB as shown in the figure if the balancing length for the two combinations of the cells are 250 cm and 400 cm. find the ratio of E_1 and E_2 .

$$\text{Ans. } E_1 - E_2 = K \times 250 \quad \text{---(1)}$$

$$E_1 + E_2 = K \times 400 \quad \text{---(2)}$$

Adding eq. (1) & (2)

$$2E_1 = 250K + 400K$$

$$2E_1 = 250K + 400$$



$$2E_1 = 650K$$

$$E_1 = \frac{650}{2} K$$

$$E_1 = 325 K \text{ ----(3)}$$

Subtracting eq. (1) & (2)

$$E_2 = 75K$$

$$\therefore \frac{E_1}{E_2} = \frac{325K}{75K}$$

$$\Rightarrow \frac{E_1}{E_2} = 4.33$$

9. Explain with the help of a circuit diagram, how the value of an unknown resistance can be determined using a wheat stone bridge?

Ans. Here P, Q, R are known resistance and X is an unknown resistance. Applying Kirchhoff's law for closed path ABDA .

$$I_1P + I_3G - I_2R = 0 \text{ ----(1)}$$

For closed path BCDB

$$(I_1 - I_3)Q - (I_2 + I_3)X - I_3G \text{ ----(2)}$$

Now the bridge is said to be balanced when

no current flows through the galvanometer

$$\Rightarrow I_g = 0$$

\(\therefore\) Eg. (1) & (2) becomes

$$I_1P = I_2R$$



$$\frac{I_1}{I_2} = \frac{R}{P} \text{ ----(3)}$$

$$I_1 Q = I_2 X$$

$$\frac{I_1}{I_2} = \frac{X}{Q} \text{ ----(4)}$$

Equating (3) & (4)

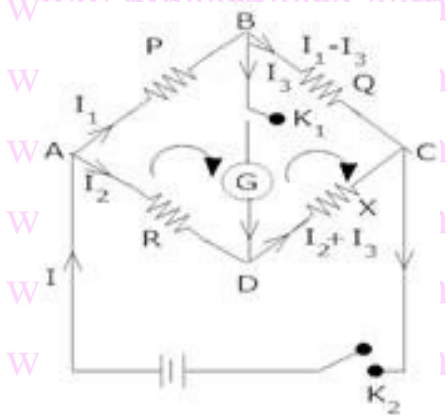

$$\frac{R}{P} = \frac{X}{Q} \Rightarrow X = \frac{RQ}{P}$$

10. Find the current drawn from a cell of emf 1V and internal resistance $2/3 \Omega$ connected to the network shown in the figure. $E = 1\text{v}$ $r = 2/3 \Omega$

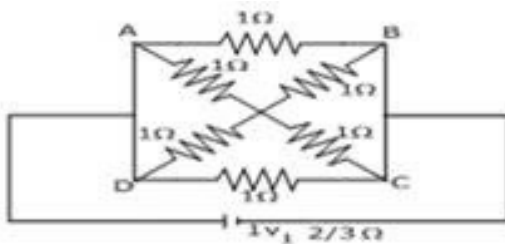

Ans. $\frac{1}{R_1} = \frac{1}{1} + \frac{1}{1}$

$$\frac{1}{R_1} = 2$$



$$\Rightarrow R_1 = \frac{1}{2}$$

$$R_2 = \frac{1}{2}$$

$$R = R_1 + R_2$$

$$\Rightarrow R = \frac{1}{2} + \frac{1}{2}$$

$$\Rightarrow R = 1 \Omega$$

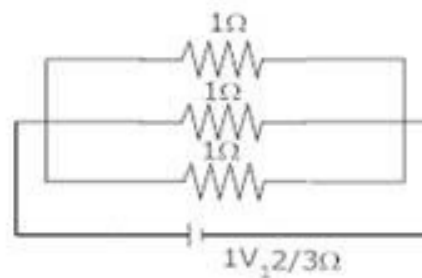
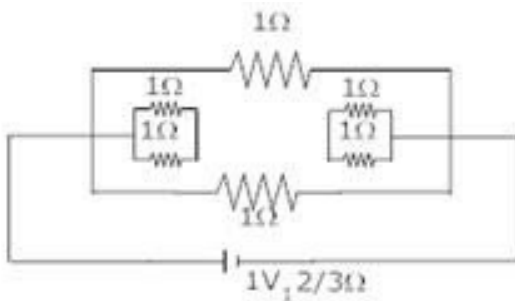

Now 1Ω , R and 1Ω are in parallel

$$\Rightarrow \frac{1}{R_{net}} = \frac{1}{1} + \frac{1}{1} + \frac{1}{1}$$

$$\frac{1}{R_{net}} = \frac{3}{1} \Rightarrow R_{net} = \frac{3}{1} \Omega$$

$$I = \frac{E}{R+r} = \frac{1}{\frac{3}{1} + \frac{3}{3}} = \frac{3}{3} = 1A$$

$I=1A$

11. (a) State and explain kirchoff's law?

(b) In the network shown, find the values of current I_1 , I_2 and I_3 .

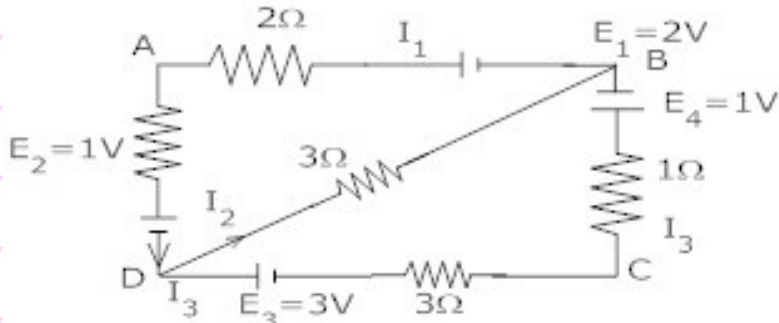

Ans. (a) Kirchoff's first law – it states that the algebraic sum of the currents meeting at a point in an electrical circuit is always zero.

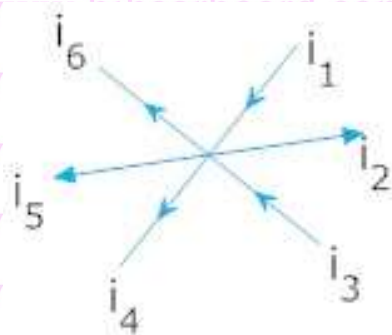

$$\Rightarrow i_1 - i_2 + i_3 - i_4 - i_5 - i_6 = 0$$

Kirchoff's second law – it states that in any closed part of an electrical circuit, the algebraic sum of emf & is equal to the algebraic sum of the products of resistances and current flowing through them for eg. For closed path ABCA

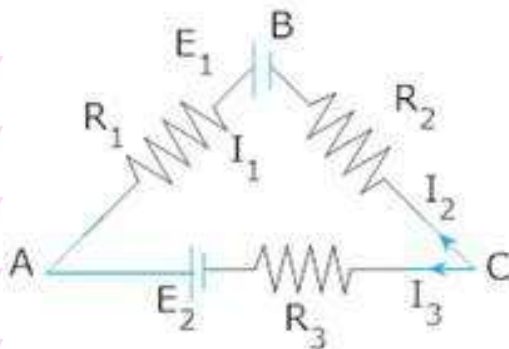

$$R_1 I_1 - R_3 I_3 + R_2 I_2 - E_1 + E_2 = 0$$

Or $E_1 - E_2 = R_1 I_1 - R_3 I_3 + R_2 I_2$



(b) Applying kirchoff's law at point -D

$$I_1 = I_2 + I_3$$

For closed path ABDA

$$2I_1 + 1 - 2 + I_1 + 3I_2 = 0$$

$$3I_1 + 3I_2 - 1 = 0$$

$$3I_1 + 3I_2 = 1 \text{ ----(2)}$$

For closed path DBCD

$$3I_2 - 1 - I_3 - 3I_3 + 3 = 0$$

$$3I_2 - 4I_3 + 2 = 0$$

Or $4I_3 - 3I_2 - 2 = 0$

$$4I_3 - 3I_2 = 2 \text{ ----(3)}$$

Solving eg. (1) , (2) & (3)

$$I_1 = \frac{13}{33} A, I_2 = \frac{-2}{33} A \text{ and } I_3 = \frac{5}{11} A$$

12. The variation of resistance of a metallic conductor with temperature is given in figure.

(a) Calculate the temperature coefficient of resistance from the graph.

(b) State why the resistance of the conductor increases with the rise in temperature.

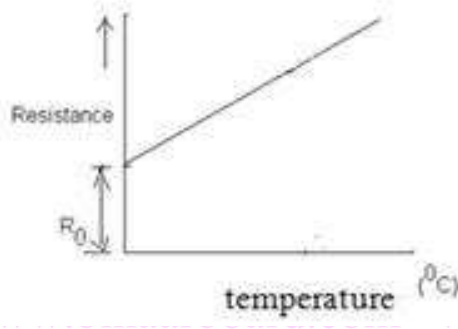
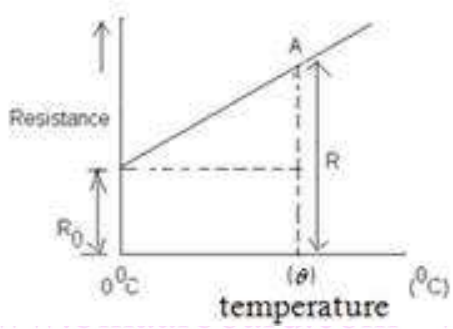

Ans. (a) Temperature coefficient of Resistance

$$\alpha = \frac{R - R_0}{R_0 \theta}$$

Where R is the resistance of the conductor and θ is the temperature corresponding to pt.A

(b) Since $R = \rho \frac{l}{A} = \frac{m}{ne^2 \tau} \left(\frac{l}{A} \right)$ $\rho = \text{Resistivity}$

When temperature increases, no of collisions increases average relaxation time decreases, hence resistance Increases.

13. A circle ring having negligible resistance is used to connect four resistors of resistances 6R , 6R , 6R and R as shown in the figure. Find the equivalent resistance.

between points A & B

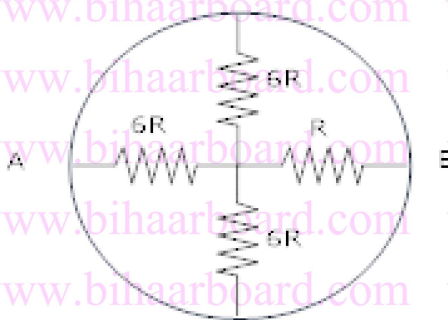

Ans.



$6R$, $6R$ and $6R$ are in parallel

$$\frac{1}{R_s} = \frac{1}{6R} + \frac{1}{6R} + \frac{1}{6R}$$

$$\frac{1}{R_s} = \frac{3}{6R}$$

$$R_s = \frac{6R}{3} = 2R$$



$R_s = 2R \Rightarrow 2R$ and R are in series

$$\therefore R_{\text{net}} = 2R + R$$

$$R_{\text{net}} = 3R$$

14. A battery of emf E and internal resistance r sends a current I_1 and I_2 , when connected to an external resistance of R_1 and R_2 respectively. Find the emf. and internal resistance of the battery?

$$\text{Ans. } I_1 = \frac{E}{R_1 + r} \Rightarrow E = I_1(R_1 + r) \quad \text{---(1)}$$

$$\text{Similarly } E = I_2(R_2 + r) \quad \text{---(2)}$$

From (1) & (2)

$$I_1(R_1 + r) = I_2(R_2 + r)$$



$$I_2 r - I_1 r = I_1 R_1 - I_2 R_2$$

$$r (I_2 - I_1) = I_1 R_1 - I_2 R_2$$

$$r = \frac{I_1 R_1 - I_2 R_2}{I_2 - I_1}$$

$$\text{Emf. (E)} = I_1 (R_1 + r)$$

$$E = I_1 \left[R_1 + \frac{I_1 R_1 - I_2 R_2}{I_2 - I_1} \right]$$

$$E = I_1 \left[\frac{I_2 R_1 - I_1 R_1 + I_1 R_1 - I_2 R_2}{I_2 - I_1} \right]$$

$$E = \frac{I_1 I_2 (R_1 - R_2)}{I_2 - I_1}$$

15. Find the value of unknown resistance X in the circuit shown in the figure if no current flows through the section AO. Also calculate the current drawn by the circuit from the battery of emf. 6v and negligible internal resistance.

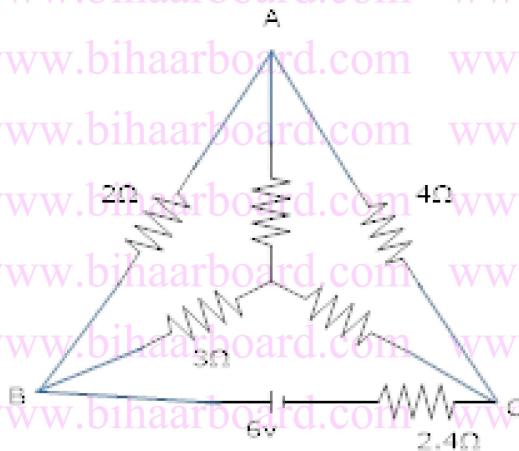

Ans. As no current flows through AO then the circuit is said to be balanced wheat Stone bridge.



$$\frac{2}{4} = \frac{3}{X}$$

$$X = \frac{12}{2} = 6$$

$$X = 6 \Omega$$

Since in branch AO, $I=0$

\therefore Resistance of 10Ω between A and O is ineffective and the circuit reduce to

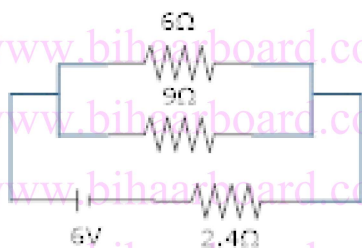
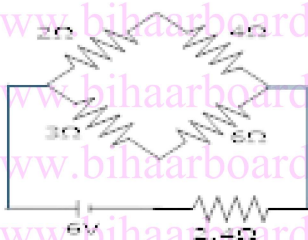

2Ω and 4Ω are in series 3Ω and 6Ω are in series

6Ω and 9Ω are in parallel

$$\therefore \frac{1}{R_p} = \frac{1}{6} + \frac{1}{9} = \frac{9+6}{54} = \frac{15}{54}$$

$$R_p = \frac{54}{15} \Omega$$

R_p and 2.4Ω are in parallel

$$R_{\text{eff}} = 2.4 + \frac{54}{15}$$



$$R_{\text{eff}} = \frac{24}{10} + \frac{54}{15} = \frac{360 + 540}{150} = \frac{900 \times 10^{-6}}{150 \times 10^{-7}}$$

$$R_{\text{eff}} = 6 \Omega$$

$$\text{Current } I = \left(\frac{V}{R} = \frac{6}{6} = 1 \right)$$

$$\Rightarrow I = 1 \text{ A}$$

16. (a) Obtain ohm's law from the expression for electrical conductivity.

(b) A cylindrical wire is stretched to increase its length by 10% calculate the percentage increase in resistance?

Ans. (a) We know $I = neAvd$

$$J = \frac{I}{A} = nev d$$

$$\text{Vol} = \frac{eE\tau}{m}$$

$$\Rightarrow J = \frac{ne^2 E \tau}{m}$$

$$\text{Since } J = \sigma E \quad \therefore \sigma = \frac{J}{E} = \frac{ne^2 \tau}{m}$$

Let l and A be the length and area of the wire.

$$I = JA$$

$$I = \frac{ne^2 E \tau}{m} \times A \quad (\because E = v/\epsilon)$$



$$\Rightarrow I = \frac{ne^2 v_d A}{m \ell} \Rightarrow V = \left(\frac{m}{ne^2 \tau} \right) \left(\frac{\ell}{A} \right) I$$

$$V = RI$$

$$\Rightarrow R = \frac{\ell}{A} \text{ where } \rho = \frac{m}{ne^2 \tau} \text{ (specific resistance of a wire)}$$

$$(b) \ell^1 = \ell + \frac{10}{100} \ell = 1.1 \ell \quad \frac{\ell^1}{\ell} = 1.1$$

Since volume of the wire remains the same

$$A \ell = A^1 \ell^1 \quad \frac{A^1}{A} = \frac{\ell}{\ell^1}$$

$$\text{Since } R = \rho \frac{\ell}{A} \text{ and } R^1 = \rho \frac{\ell^1}{A^1}$$

$$\therefore \frac{R^1}{R} = \frac{\ell^1}{A^1} \times \frac{A}{\ell} = \frac{\ell^1}{\ell} \times \frac{\ell}{\ell^1} = \left(\frac{\ell^1}{\ell} \right)^2$$

$$\frac{R^1}{R} = (1.1)^2 = 1.21$$

\(\therefore\) Percentage increase in Resistance is

$$\frac{R^1 - R}{R} \times 100 = 21\%$$

17. The current I flows through a wire of radius r and the free electron drift with a velocity v_d what is the drift velocity of electrons through a wire of same material but having double the radius, when a current of $2I$ flows through it?

Ans. $I = ne A v_d$



$$\Rightarrow vd = \frac{I}{neA} = \frac{I}{ne\pi r^2} \quad (1)$$

If vd' is the drift velocity of electrons in the second wire

$$Vd' = \frac{I'}{nA'e} \Rightarrow vd' = \frac{2I}{n4\pi r^2 e} = \frac{1}{2} \left(\frac{I}{n\pi r^2 e} \right) \quad (2)$$

From eq. (1) & (2)

$$vd' = \frac{vd}{2}$$

18. Three identical cells, each of emf. 2v and unknown internal resistance are connected in parallel .This combination is connected to a 5ohm resister. If the terminal voltage across the cell is 1.5volt. What is the internal resistance of each cell .hence define internal resistance of a cell?

Ans. $E = 2v, V=1.5v, R = 5 \Omega$

$$\text{Total internal resistance} = \frac{r}{3}$$

$$\text{Since } r = \left(\frac{E}{V} - 1 \right) R$$

$$\frac{r}{3} = \left(\frac{2}{1.5} - 1 \right) 5$$

$$\frac{r}{3} = \left(\frac{2-1.5}{1.5} \right) 5$$

$$r = 15 \left(\frac{0.5}{1.5} \right)$$

$$r = 50 \text{ hm}$$

The resistance offered by the electrolyte of the cell, when the electric current flows through it



, is called as internal resistance of a cell.

19. Using Kirchoff's law, determine the current I_1 , I_2 and I_3 for the network shown.

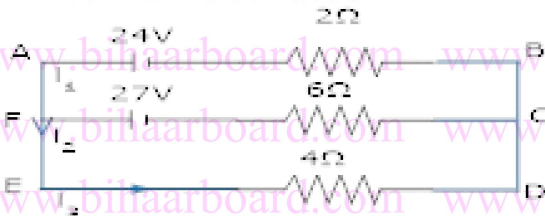

Ans. Applying junction rule at point F

$$I_1 = I_2 + I_3 \text{ ---(1)}$$

Loop rule for BAFCB

$$2I_1 + 6I_2 - 24 + 27 = 0$$

$$2I_1 + 6I_2 + 3 = 0 \text{ b ---(2)}$$

Loop rule for FCDEF

$$27 + 6I_2 - 4I_3 = 0 \text{ ---(3)}$$

solving eq . (1), (2) & (3) we get

$$I_1 = 3A, I_2 = -1.5A, I_3 = 4.5A$$

20. Show that when a current is divided between two resistances in accordance with kirchoff's laws, the heat provided is minimum?

Ans. Consider two resistance R_1 and R_2 in parallel and i_1 and i_2 be the current. Using kirchoff's first law

$$i = i_1 + i_2 \text{ ---(1)}$$

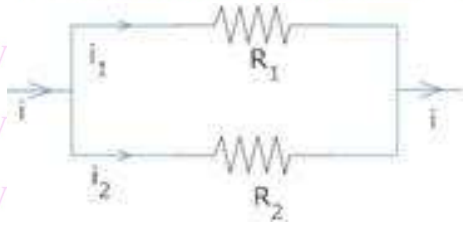

kirchoff's second law

$$i_1 R_1 - i_2 R_2 = 0$$

$$\frac{i_1}{i_2} = \frac{R_2}{R_1} \quad \text{-----(2)}$$

Heat produced in the circuit in t second is

$$H = i_1^2 R_1 t + i_2^2 R_2 t$$

$$H = i_1^2 R_1 t + (i - i_1)^2 R_2 t \quad (\text{using eg.(1)})$$

If the heat produced is minimum then $\frac{dH}{di_1} = 0$

$$\therefore 0 = 2i_1 R_1 t + 2(i - i_1) (-1) R_2 t$$

$$\cancel{2} (i - i_1) R_2 \cancel{t} = \cancel{2} i_1 R_1 \cancel{t}$$

$$(i - i_1) R_2 = i_1 R_1$$

$$\frac{i_1}{i_2} = \frac{R_2}{R_1} \quad \text{This is in accordance with kirchoff's law.}$$

21. (a) Define emf. of a cell? On what factors does it depend?

(b) Figure below shows a 2.0v potentiometer used for the determination of internal resistance of a 1.5v cell. The balance point of the cell in open circuit is 76.3cm. When a resistance of 9.5 Ω is used in external circuit of the cell the balance point shifts to 64.8cm length of the potentiometer. Determine the internal resistance of the cell.

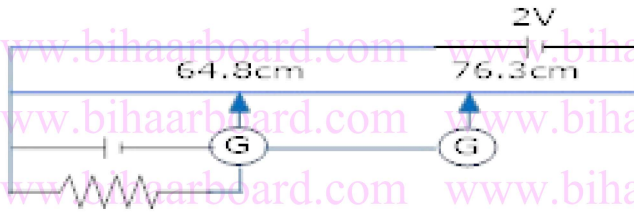

Ans. (a) It is defined as the potential difference between the two electrodes of the cell in open Circuit (when no current is drawn) It depends on the following factors

- (i) Nature of Electrodes
- (ii) Nature and concentration of the Electrolytes
- (iii) Temperature of the cell.

(b) Internal resistance of the cell.

$$r = R \left(\frac{\ell_1 - \ell_2}{\ell_2} \right)$$

Here $\ell_1 = 76.3 \text{ cm}$

$\ell_2 = 64.8 \text{ cm}$

$R = 9.5 \Omega$

$$\Rightarrow r = 9.5 \left(\frac{76.3 - 64.8}{64.8} \right)$$

$r = 1.68 \Omega$

22. A battery of emf 10 V and internal resistance 3 Ω is connected resistor. If the current in the circuit is 0.5 A, what is the resistance of the resistor? What is the terminal voltage of the battery when the circuit is closed?

Ans. Emf of the battery, $E = 10 \text{ V}$

Internal resistance of the battery, $r = 3 \Omega$



Current in the circuit, $I=0.5\text{A}$

Resistance of the resistor = R

The relation for current using Ohm's law is,

$$I = \frac{E}{R+r}$$

$$R+r = \frac{E}{I}$$

$$= \frac{10}{0.5} = 20\Omega$$

$$\therefore R = 20 - 3 = 17\Omega$$

Terminal voltage of the resistor = V

According to Ohm's law,

$$V=IR$$

$$= 0.5 \times 17$$

$$= 8.5\text{V}$$

Therefore, the resistance of the resistor is 17Ω and the terminal voltage is 8.5v .

23. (a) Three resistors 1Ω , 2Ω and 3Ω are combined in series. What is the total resistance of the combination?

(b) If the combination is connected to a battery of emf 12V and negligible internal resistance, obtain the potential drop across each resistor.

Ans.(a) Three resistors of resistances 1Ω , 2Ω and 3Ω are combined in series. Total resistance of the combination is given by the algebraic sum of individual resistances.

$$\text{Total resistance} = 1 + 2 + 3 = 6\Omega$$



(b) Current flowing through the circuit= I

Emf of the battery, $E=12V$

Total resistance of the circuit, $R=6\Omega$

The relation for current using Ohm's law is,

$$I = \frac{E}{R}$$

$$= \frac{12}{6} = 2A$$

Potential drop across 1Ω resistor = V_1

For Ohm's law, the value of V_1 can be obtained as

$$V_1 = 2 \times 1 = 2V \dots\dots (i)$$

Potential drop across 2Ω resistor = V_2

Again, from Ohm's law, the value of V_2 can be obtained as

$$V_2 = 2 \times 2 = 4V \dots\dots (ii)$$

Potential drop across 3Ω resistor = V_3

Again, from Ohm's law, the value of V_3 can be obtained as

$$V_3 = 2 \times 3 = 6V \dots\dots (iii)$$

Therefore, the potential drop across 1Ω , 2Ω and 3Ω resistors are 2V, 4V, and 6V respectively.

24. At room temperature ($27.0^\circ C$) the resistance of a heating element is 100Ω . What is the temperature of the element if the resistance is found to be 117Ω , given that the temperature coefficient of the material of the resistor is $1.70 \times 10^{-4} ^\circ C^{-1}$



Ans. Room temperature, $T=27^{\circ}\text{C}$

Resistance of the heating element at $T_1, R_1=117\Omega$

Temperature co-efficient of the material of the filament,

$$\alpha = 1.70 \times 10^{-4} \text{ }^{\circ}\text{C}^{-1}$$

α is given by the relation,

$$\alpha = \frac{R_1 - R}{R(T_1 - T)}$$

$$T_1 - T = \frac{R_1 - R}{R\alpha}$$

$$T_1 - 27 = \frac{117 - 100}{100(1.7 \times 10^{-4})}$$

$$T_1 - 27 = 1000$$

Therefore, at 1027°C , the resistance of the element is 117Ω .

25. A negligibly small current is passed through a wire of length 15 m and uniform cross section $= 6.0 \times 10^{-7} \text{ m}^2$, and its resistance is measured to be 5.0Ω . What is the material at the temperature of the experiment?

Ans. Resistivity of material can be calculated as:

Length of the wire, $l=15\text{m}$

Area of cross-section of the wire, $a = 6.0 \times 10^{-7} \text{ m}^2$

Resistance of the material of the wire, $R = 5.0 \Omega$

Resistivity of the material of the wire= ρ

Resistance is related with the resistivity as:



$$R = \rho \frac{l}{A}$$
$$\rho = \frac{RA}{l}$$
$$= \frac{5 \times 6 \times 10^{-7}}{15}$$
$$= 2 \times 10^{-7} \Omega m$$

Therefore, the resistivity of the material is $2 \times 10^{-7} \Omega m$.

26. A silver wire has a resistance of 2.1Ω at $27.5^\circ C$, and a resistance of 2.7Ω at $100^\circ C$. Determine the temperature coefficient of resistivity of silver.

Ans. Temperature, $T_1 = 27.5^\circ C$

Resistance of the silver wire at $T_1, R_1 = 2.1 \Omega$

Temperature, $T_2 = 100^\circ C$

Resistance of the silver wire at $T_2, R_2 = 2.7 \Omega$

Temperature coefficient of silver = α

It is related with temperature and resistance as

$$\alpha = \frac{R_2 - R_1}{R_1(T_2 - T_1)}$$
$$= \frac{2.7 - 2.1}{2.1(100 - 27.5)}$$

$$= 0.0039^\circ C^{-1}$$

Therefore, the temperature coefficient of silver is $0.0039^\circ C^{-1}$.



27. A heating element using nichrome connected to a 230 V supply draws an initial current of 3.2 A which settles after a few seconds to a steady value of 2.8 A. What is the steady temperature of the heating element if the room temperature is 27.0 °C?

Temperature coefficient of resistance of nichrome averaged over the temperature range involved is $= 1.7 \times 10^{-4} \text{ } ^\circ\text{C}^{-1}$.

Ans. Supply voltage, $V = 230\text{V}$

Initial current drawn = $I_1 = 3.2\text{A}$

Initial resistance = R_1 , which is given by the relation,

$$R_1 = \frac{V}{I}$$
$$= \frac{230}{3.2} = 71.87\Omega$$

Steady state value of the current, $I_2 = 2.8\text{A}$

Resistance at the steady state = R_2 , which is given as

$$R_2 = \frac{230}{2.8} = 82.14\Omega$$

Temperature co-efficient of nichrome, $\alpha = 1.70 \times 10^{-4} \text{ } ^\circ\text{C}^{-1}$

Initial temperature of nichrome, $T_1 = 27.0^\circ\text{C}$

Steady state temperature reached by nichrome = T_2

T_2 can be obtained by the relation for α ,

$$\alpha = \frac{R_2 - R_1}{R_1 (T_2 - T_1)}$$

$$T_2 - 27^\circ\text{C} = \frac{82.14 - 71.87}{71.87 \times 1.7 \times 10^{-4}} = 840.5$$



$$T_2 = 840.5 + 27 = 867.5^\circ\text{C}$$

Therefore, the steady temperature of the heating element is 867.5°C

28. A storage battery of emf 8.0 V and internal resistance $0.5\ \Omega$ is being charged by a 120 V dc supply using a series resistor of $15.5\ \Omega$. What is the terminal voltage of the battery during charging? What is the purpose of having a series resistor in the charging circuit?

Ans. Emf of the storage battery, E

Internal resistance of the battery, $r = 0.5\ \Omega$

DC supply voltage, $V = 120\ \text{V}$

Resistance of the resistor, $R = 15.5\ \Omega$

Effective voltage in the circuit = $V - E$

R is connected to the storage battery in series. Hence, it can be written as

$$V_1 = V - E$$

$$V_1 = 120 - 8 = 112\ \text{V}$$

Current flowing in the circuit can be calculated as:

Voltage across resistor R is given by the product, $IR = 7 \times 15.5 = 108.5\ \text{V}$

DC supply voltage = Terminal voltage of battery + Voltage drop across R

Terminal voltage of battery = $120 - 108.5 = 11.5\ \text{V}$ A series resistor in a charging circuit limits

the current drawn from the external source. The current will be

extremely high in its absence. This is very dangerous.

29. The number density of free electrons in a copper conductor estimated in Example is

$8.5 \times 10^{28}\ \text{m}^{-3}$. How long does an electron take to drift from one end of a wire 3.0 m



long to its other end? The area of cross section of the wire is $2 \times 10^{-6} \text{ m}^2$ and it is carrying a current of 3.0 A.

Ans. Number density of free electrons in a copper conductor, $n = 8.5 \times 10^{28} \text{ m}^{-3}$

Length of the copper wire, $l = 3.0 \text{ m}$

Area of cross-section of the wire, $A = 2.0 \times 10^{-6} \text{ m}^2$

Current carried by the wire, $I = 3.0 \text{ A}$, Which is given by the relation,

$$I = nAeVd$$

Where,

e = Electric charge = $1.6 \times 10^{-19} \text{ C}$

$$V_d = \text{Drift velocity} = \frac{\text{Length of the wire}}{\text{Time taken to cover}}$$

$$I = nAe \frac{l}{t}$$

$$t = \frac{nAel}{I}$$

$$= \frac{3 \times 8.5 \times 2 \times 10^{-6} \times 1.6 \times 10^{-19}}{3.0}$$

$$= 2.7 \times 10^4 \text{ s}$$

Therefore, the time taken by an electron to drift from one end of wire to the other is

$$2.7 \times 10^4 \text{ s}$$

30. The earth's surface has a negative surface charge density of 10^{-9} C m^{-2} . The potential difference of 400 kV between the top of the atmosphere and the surface results (due to the low conductivity of the lower atmosphere) in a current of only 1800 A over the entire globe. If there were no mechanism of sustaining atmospheric electric



field, how much time (roughly) would be required to neutralise the earth's surface? (This never happens in practice because there is a mechanism to replenish electric charges, namely the continual thunderstorms and lightning in different part of the globe [Radius of earth = $6.37 \times 10^6 \text{ m}$.]

Ans. Surface charge density of the earth, $\delta = 10^{-9} \text{ C m}^{-2}$

Current over the entire globe, $I = 1800 \text{ A}$

Radius of the earth, $r = 6.37 \times 10^6 \text{ m}$.

Surface area of the earth,

$$\begin{aligned} A &= 4\pi r^2 \\ &= 4\pi(6.37 \times 10^6)^2 \\ &= 5.091014 \times 10^{14} \text{ m}^2 \end{aligned}$$

Charge on the earth surface,

$$\begin{aligned} q &= \sigma \times A \\ &= 10^{-9} \times 5.09 \times 10^{14} \\ &= 5.09 \times 10^5 \text{ C} \end{aligned}$$

Time taken to neutralize the earth's surface = t Current,

$$\begin{aligned} I &= \frac{q}{t} \\ t &= \frac{q}{I} \\ &= \frac{5.09 \times 10^5}{1800} = 282.77 \text{ s} \end{aligned}$$

Therefore, the time taken to neutralize the earth's surface is 282.77s.



31. Choose the correct alternative:

- (a) Alloys of metals usually have (greater/less) resistivity than that of their constituent metals.
- (b) Alloys usually have much (lower/higher) temperature coefficients of resistance than pure metals.
- (c) The resistivity of the alloy manganin is nearly independent of/increases rapidly with increase of temperature.
- (d) The resistivity of a typical insulator (e.g., amber) is greater than that of a metal by a factor of the order of $(10^{22} / 10^3)$.

Ans. (a) Alloys of metals usually have greater resistivity than that of their constituent metals.

(b) Alloys usually have lower temperature coefficients of resistance than pure metals.

(c) The resistivity of the alloy, manganin, is nearly independent of increase of temperature.

(d) The resistivity of a typical insulator is greater than that of a metal by a factor of the order of 10^{22} .

32. Determine the current drawn from a 12 V supply with internal resistance 0.5Ω by the infinite network shown in Fig 3.32. Each resistor has 1Ω resistance.

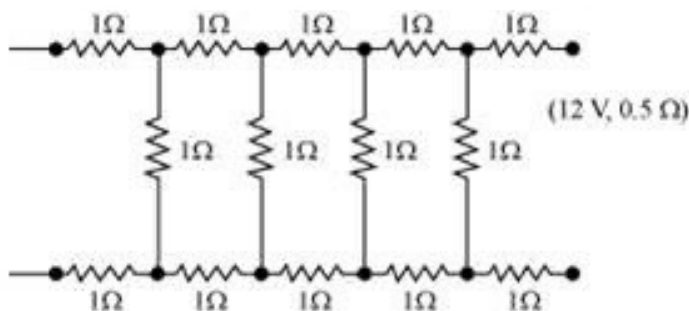

Ans. The resistance of each resistor connected in the given circuit, $R = 1 \Omega$

Equivalent resistance of the given circuit = R



The network is infinite, Hence, equivalent resistance is given by the relation,

$$\therefore R' = 2 + \frac{R'}{R+1}$$

$$(R)^2 - 2R - 2 = 0$$

$$R' = \frac{2 \pm \sqrt{4+8}}{2}$$

$$= \frac{2 \pm \sqrt{12}}{2} = 1 \pm \sqrt{3}$$

Negative value of R' cannot be accepted. Hence, equivalent resistance,

$$R' = (1 + \sqrt{3}) = 1 + 1.73 = 2.73 \Omega$$

Internal resistance of circuit is 0.5Ω

Hence, total resistance of the given circuit = $2.73 + 0.5 = 3.23 \Omega$

Supply Voltage, $V = 12V$

According to Ohm's Law, current drawn from the source is given by the ratio,

$$\frac{12}{3.23} = 3.72A$$

33. Figure 3.34 shows a potentiometer circuit for comparison of two resistances. The balance point with a standard resistor $R = 10.0 \Omega$ is found to be 58.3 cm, while that with the unknown resistance X is 68.5 cm. Determine the value of X . What might you do if you failed to find a balance point with the given cell of emf \mathcal{E} ?

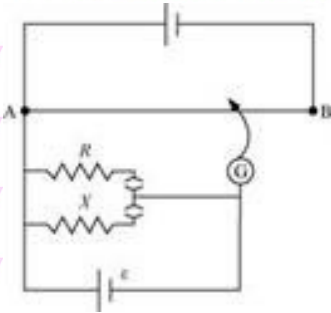

Ans. Resistance of the standard resistor, $R = 10.0 \Omega$

Balance point for this resistance, $l_1 = 58.3 \text{ cm}$

Current in the potentiometer wire = i

Hence, potential drop across R , $E_1 = iR$

Resistance of the unknown resistor = X

Balance point for this resistor, $l_2 = 68.5 \text{ cm}$

Hence, potential drop across X , $E_2 = iX$

The relation connecting emf and balance point is,

$$\frac{E_1}{E_2} = \frac{l_1}{l_2}$$

$$\frac{iR}{iX} = \frac{l_1}{l_2}$$

$$X = \frac{l_1}{l_2} \times R$$

$$= \frac{68.5}{58.3} \times 10 = 11.749 \Omega$$

Therefore, the value of the unknown resistance, X , is 11.75Ω .

If we fail to find a balance point with the given cell of emf, \mathcal{E} , then the potential drop across



And X must be reduced by putting a resistance in series with it. Only if the potential drop across R or X is smaller than the potential drop across the potentiometer wire AB , a balance point is obtained.

34. Figure shows a 2.0 V potentiometer used for the determination of internal resistance of a 1.5 V cell. The balance point of the cell in open circuit is 76.3 cm. When a resistor of 9.5Ω is used in the external circuit of the cell, the balance point shifts to 64.8 cm length of the potentiometer wire. Determine the internal resistance of the cell.

Ans. Internal resistance of the cell = r

Balance point of the cell in open circuit, $l_1 = 76.3 \text{ cm}$

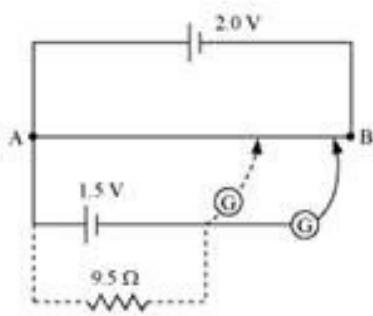

An external resistance (R) is connected to the circuit with $R = 9.5 \Omega$

New balance point of the circuit, $l_2 = 64.8 \text{ cm}$

Current flowing through the circuit = I

The relation connecting resistance and emf is,

$$r = \left(\frac{l_2 - l_1}{l_2} \right) R$$

$$= \frac{76.3 - 64.8}{64.8} \times 9.5 = 1.68 \Omega$$

Therefore, the internal resistance of the cell is 1.68Ω .

**5 Mark Questions**

1. (a) Three resistors $2\ \Omega$, $4\ \Omega$ and $5\ \Omega$ are combined in parallel. What is the total resistance of the combination?

(b) If the combination is connected to a battery of emf $20\ \text{V}$ and negligible internal resistance, determine the current through each resistor, and the total current drawn from the battery.

Ans. (a) There are three resistors of resistances,

$$R_1 = 2, R_2 = 4, \text{ and } R_3 = 5$$

They are connected in parallel. Hence, total resistance (R) of the combination is given by,

$$\frac{1}{R} = \frac{1}{R_1} + \frac{1}{R_2} + \frac{1}{R_3}$$

$$= \frac{1}{2} + \frac{1}{4} + \frac{1}{5} = \frac{10 + 5 + 4}{20} = \frac{19}{20}$$

$$\therefore R = \frac{20}{19}\ \Omega$$

Therefore, total resistance of the combination is $\frac{20}{19}\ \Omega$.

(b) Emf of the battery, $V = 20\ \text{V}$

Current (I_1) flowing through resistor R_1 is given by,

$$I_1 = \frac{V}{R_1}$$

$$= \frac{20}{2} = 10\ \text{A}$$



Current (I_1) flowing through resistor R_1 is given by,

$$I_1 = \frac{V}{R_1} \\ = \frac{20}{4} = 5A$$

Current (I_3) flowing through resistor R_3 is given by,

$$I_3 = \frac{V}{R_3} \\ = \frac{20}{5} = 4A$$

Total current, $I = I_1 + I_2 + I_3 = 10 + 5 + 4 = 19A$

Therefore, the current through each resistor is 10A, 5A, and 4A respectively and the total current is 19A.

2. Determine the current in each branch of the network shown in fig 3.30:

Ans. Current flowing through various branches of the circuit is represented in the given figure.

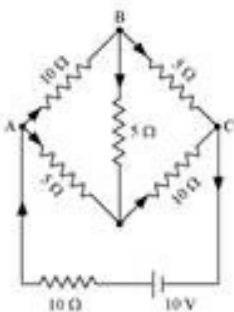



I_1 = Current flowing through the outer circuit

I_2 = Current flowing through branch AB

I_3 = Current flowing through branch AD

$I_2 - I_4$ = Current flowing through branch BC

$I_3 + I_4$ = Current flowing through branch CD

I_4 = Current flowing through branch BD

For the closed circuit ABDA, potential is zero i.e.,

$$10I_2 + 5I_4 - 5I_3 = 0$$

$$2I_2 + I_4 - I_3 = 0$$

$$I_3 = 2I_2 + I_4 \dots (1)$$

For the closed circuit BCDB, potential is zero i.e.,

$$5(I_2 - I_4) - 10(I_3 + I_4) - 5I_4 = 0$$

$$5I_2 + 5I_4 - 10I_3 - 10I_4 - 5I_4 = 0$$

$$5I_2 - 10I_3 - 20I_4 = 0$$

$$I_2 = 2I_3 + 4I_4 \dots (2)$$

For the closed circuit ABCFEA, potential is zero i.e.,

$$-10 + 10(I_1) + 10(I_2) + 5(I_2 - I_4) = 0$$

$$10 = 15I_2 + 10I_1 - 5I_4$$



$$3I_2 + 2I_1 - I_4 = 2 \dots (3)$$

From equations (1) and (2), we obtain

$$I_3 = 2(2I_3 + 4I_4) + I_4$$

$$I_3 = 4I_3 + 8I_4 + I_4$$

$$-3I_3 = 9I_4$$

$$-3I_4 = +I_3 \dots (4)$$

Putting equation (4) in equation (1), we obtain

$$I_3 = 2I_2 + I_4$$

$$-4I_4 = 2I_2$$

$$I_2 = -2I_4 \dots (5)$$

It is evident from the given figure that,

$$I_1 = I_3 + I_2 \dots (6)$$

Putting equation (6) in equation (1), we obtain

$$3I_2 + 2(I_3 + I_2) - I_4 = 2$$

$$5I_2 + 2I_3 - I_4 = 2 \dots (7)$$

Putting equations (4) and (5) in equation (7), we obtain

$$5(-2I_4) + 2(-3I_4) - I_4 = 2$$

$$10I_4 - 6I_4 - I_4 = 2$$



$$17I_4 = -2$$

Equation (4) reduces to

$$I_3 = -3(I_4)$$

$$= -3\left(\frac{-2}{17}\right) = \frac{6}{17} \text{ A}$$

$$I_2 = -2(I_4)$$

$$= -2\left(\frac{-2}{17}\right) = \frac{4}{17} \text{ A}$$

$$I_2 - I_4 = \frac{4}{17} - \left(\frac{-2}{17}\right) = \frac{6}{17} \text{ A}$$

$$I_3 + I_4 = \frac{6}{17} + \left(\frac{-2}{17}\right) = \frac{4}{17} \text{ A}$$

$$I_1 = I_3 + I_2$$

$$= \frac{6}{17} + \frac{4}{17} = \frac{10}{17} \text{ A}$$

Therefore, current in branch $AB = \frac{4}{17} \text{ A}$

In branch $BC = \frac{6}{17} \text{ A}$

In branch $CD = \frac{-4}{17} \text{ A}$

In branch $AD = \frac{6}{17} \text{ A}$



In branch $BD = \frac{-2}{17} \text{ A}$

Therefore total current $= \frac{4}{17} + \frac{6}{17} + \frac{-4}{17} + \frac{6}{17} + \frac{-2}{17} = \frac{10}{17} \text{ A}$

3. (a) In a metre bridge [Fig. 3.27], the balance point is found to be at 39.5 cm from the end when the resistor Y is of 12.5Ω .

(b) Determine the balance point of the bridge above if X and Y are interchanged.

(c) What happens if the galvanometer and cell are interchanged at the balance point of the bridge? Would the galvanometer show any current?

Ans. A metre bridge with resistors X and Y is represented in the given figure.

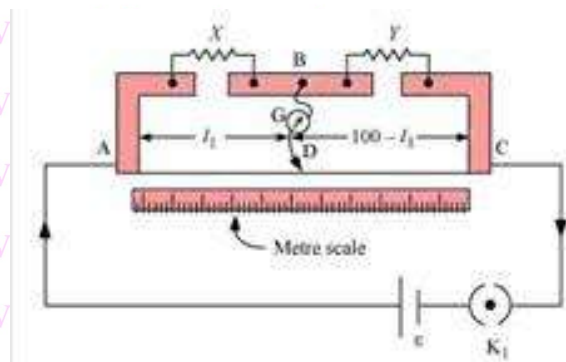

(a) Balance point from end $A, l_1 = 39.5 \text{ cm}$

Resistance of the resistor $Y = 12.5 \Omega$

Condition for the balance is given as,

$$\frac{X}{Y} = \frac{100 - l_1}{l_1}$$

$$X = \frac{100 - 39.5}{39.5} \times 12.5 = 8.2 \Omega$$

Therefore, the resistance of resistor X is 8.2Ω .



The connection between resistors in a Wheatstone or metre bridge is made of thick copper strips to minimize the resistance, which is not taken into consideration in the bridge formula.

If X and Y are interchanged, then l_1 and $100 - l_1$ get interchanged.

The balance point of the bridge will be $100 - l_1$ from A.

$$100 - l_1 = 100 - 39.5 = 60.5 \text{ cm}$$

Therefore, the balance point is 60.5 cm from A.

When the galvanometer and cell are interchanged at the balance point of the bridge, the galvanometer will show no deflection. Hence, no current would flow through the galvanometer.

4. (a) Six lead-acid type of secondary cells each of emf 2.0 V and internal resistance 0.015 Ω are joined in series to provide a supply to a resistance of 8.5 Ω . What are the current drawn from the supply and its terminal voltage?

(b) A secondary cell after long use has an emf of 1.9 V and a large internal resistance of 380 Ω . What maximum current can be drawn from the cell? Could the cell drive the starting motor of a car?

Ans. (a) Number of secondary cells, n

Emf of each secondary cell, $E = 2.0 \text{ V}$

Internal resistance of each cell, $r = 0.015 \Omega$

series resistor is connected to the combination of cells.

Resistance of the resistor, $R = 8.5 \Omega$

Current drawn from the supply = I , which is given by the relation,

$$I = \frac{nE}{R + nr}$$



$$= \frac{6 \times 2}{8.5 + 6 \times 0.015}$$

$$= \frac{12}{8.59} = 1.39 \text{ A}$$

Terminal voltage, $V = IR = 1.39 \times 8.5 = 11.87 \text{ A}$

Therefore, the current drawn from the supply is 1.39 A and terminal voltage is 11.87 A.

After a long use, emf of the secondary cell, $E = 1.9 \text{ V}$

Internal resistance of the cell, $r = 380 \Omega$

$$\text{Maximum current } E = \frac{E}{r} = \frac{1.9}{380} = 0.005 \text{ A}$$

Therefore, the maximum current drawn from the cell is 0.005 A. Since a large current is required to start the motor of a car, the cell cannot be used to start a motor.

5. Two wires of equal length, one of aluminium and the other of copper have the same resistance. Which of the two wires is lighter? Hence explain why aluminium wires are preferred for overhead power cables. ($\rho_{\text{Al}} = 2.63 \times 10^{-8} \Omega \text{ m}$, $\rho_{\text{Cu}} = 1.72 \times 10^{-8} \Omega \text{ m}$,

Relative density of Al = 2.7, of Cu = 8.9.)

Ans. Resistivity of aluminium, $\rho_{\text{Al}} = 2.63 \times 10^{-8} \text{ m}$

Relative density of aluminium, $d_1 = 2.7$

Let l_1 be the length of aluminium wire and m_1 be its mass.

Resistance of the aluminium wire = R_1

Area of cross-section of the aluminium wire = A_1

Resistivity of copper, $\rho_{\text{Cu}} = 1.72 \times 10^{-8} \text{ m}$

Relative density of copper, $d_2 = 8.9$



Let l_1 be the length of copper wire and m_1 be its mass.

Resistance of the copper wire = R_1

Area of cross-section of the copper wire = A_1

The two relations can be written as

$$R_1 = \rho_1 \frac{l_1}{A_1} \dots\dots(1)$$

$$R_2 = \rho_2 \frac{l_2}{A_2} \dots\dots(2)$$

It is given that,

$$R_1 = R_2$$

$$\therefore \rho_1 = \frac{l_1}{A_1} = \rho_2 = \frac{l_2}{A_2}$$

And,

$$l_1 = l_2$$

$$\therefore \frac{\rho_1}{A_1} = \frac{\rho_2}{A_2}$$

$$\frac{A_1}{A_2} = \frac{\rho_1}{\rho_2}$$

$$= \frac{2.63 \times 10^{-8}}{1.72 \times 10^{-8}} = \frac{2.63}{1.72}$$

Mass of the aluminium wire,

$$m_1 = \text{Volume} \times \text{Density}$$



$$= A_1 l_1 \times d_1 = A_1 l_1 d_1 \dots\dots(3)$$

Mass of the copper wire,

$$m_2 = \text{Volume} \times \text{Density}$$

$$= A_2 l_2 \times d_2 = A_2 l_2 d_2 \dots\dots(4)$$

Dividing equation (3) by equation (4), we obtain

$$\frac{m_1}{m_2} = \frac{A_1 l_1 d_1}{A_2 l_2 d_2}$$

For $l_1 = l_2$,

$$\frac{m_1}{m_2} = \frac{A_1 l_1}{A_2 l_2}$$

For $\frac{A_1}{A_2} = \frac{2.63}{1.72}$,

$$\frac{m_1}{m_2} = \frac{2.63}{1.72} \times \frac{2.7}{8.9} = 0.46$$

It can be inferred from this ratio that m_1 is less than m_2 . Hence, aluminium is lighter than copper.

Since aluminium is lighter, it is preferred for overhead power cables over copper.

6. Answer the following questions:

[a] A steady current flows in a metallic conductor of non-uniform cross section of non-uniform cross section. Which of these quantities is constant along the conductor: current, current density, electric field, drift speed?

[b] Is Ohm's law universally applicable for all conducting elements?

If not, give examples of elements which do not obey Ohm's law.



[c] A low voltage supply from which one needs high currents must have very low resistance. Why?

[d] A high tension (HT) supply of, say, 6 kV must have a very large internal resistance

Ans.

[a] When a steady current flows in a metallic conductor of non-uniform cross section, the current flowing through the conductor is constant. Current density, electric field, and drift speed are inversely proportional to the area of cross-section. Therefore, they are not constant.

[b] No, Ohm's law is not universally applicable for all conducting elements. Vacuum diode semi-conductor is a non-ohmic conductor. Ohm's law is not valid for it.

[c] According to Ohm's law, the relation for the potential is $V=IR$

Voltage (V) is directly proportional to current (I).

R is the internal resistance of the source,

$$I = \frac{V}{R}$$

If V is low, then R must be very low, so that high current can be drawn from the source.

[d] In order to prohibit the current from exceeding the safety limit, a high tension supply must have a very large internal resistance. If the internal resistance is not large, then the current drawn can exceed the safety limits in case of a short circuit.

7. [a] Given n resistors each of resistance R , how will you combine them to get the (i) maximum (ii) minimum effective resistance? What is the ratio of the maximum to minimum resistance?

[b] Given the resistances of 1Ω , 2Ω , 3Ω , how will be combine them to get an equivalent resistance of

(i) $(11/3) \Omega$, (ii) $(11/5) \Omega$, (iii) 6Ω , (iv) $(6/11) \Omega$?



[c] Determine the equivalent resistance of networks shown in fig.3.31.

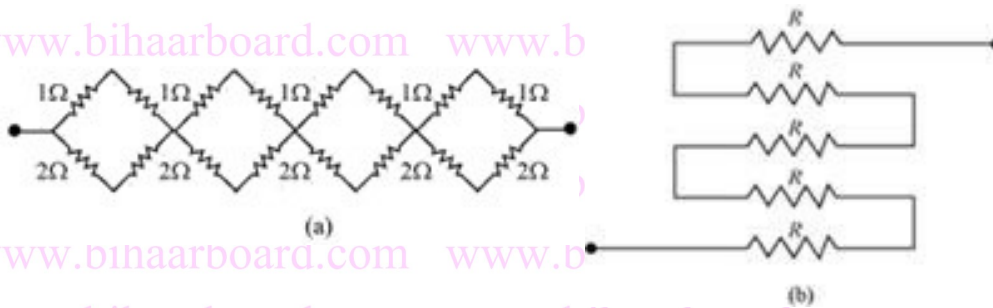

Ans. (a) Total number of resistors = n

Resistance of each resistor = R

(i) When n resistors are connected in series, effective resistance R_1 is the maximum, given by the product nR .

Hence, maximum resistance of the combination, $R_1 = nR$

(ii) When n resistors are connected in parallel, the effective resistance (R_2) is the minimum,

given by the relation $\frac{R}{n}$.

Hence, minimum resistance of the combination, $R_2 = \frac{R}{n}$

(iii) The ratio of the maximum to the minimum resistance is,

$$\frac{R_1}{R_2} = \frac{nR}{\frac{R}{n}} = n^2$$

(b) The resistance of the given resistors is,

$$R_1 = 1\Omega, R_2 = 2\Omega, R_3 = 3\Omega$$

i. Equivalent resistance, $R' = \frac{11}{3}\Omega$

Consider the following combination of the resistors.



Equivalent resistance of the circuit is given by,

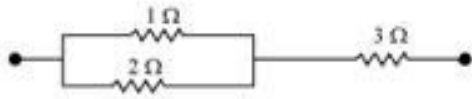

$$R' = \frac{2 \times 1}{2 + 1} + 3 = \frac{2}{3} + 3 = \frac{11}{3} \Omega$$

ii. Equivalent resistance, $R' = \frac{11}{5} \Omega$

Equivalent resistance of the circuit is given by,

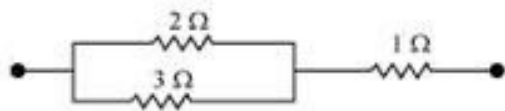

$$R' = \frac{2 \times 3}{2 + 3} + 1 = \frac{6}{5} + 1 = \frac{11}{5} \Omega$$

iii. Equivalent resistance, $R' = 6 \Omega$

Consider the series combination of the resistors, as shown in the given circuit.

Equivalent resistance of the circuit is given by the sum,

$$R' = 1 + 2 + 3 = 6 \Omega$$

Consider the series combination of the resistors, as shown in the given circuit. Equivalent resistance of the circuit is given by,

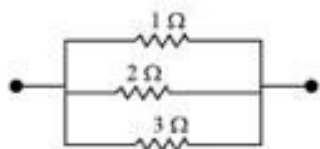

$$R' = \frac{1 \times 2 \times 3}{1 \times 2 + 2 \times 3 + 3 \times 1} = \frac{6}{11} \Omega$$

(c) (i) It can be observed from the given circuit that in the first small loop, two resistors of



resistance 1Ω each are connected in series.

Hence, their equivalent resistance = $(1+1) = 2\Omega$

It can also be observed that two resistors of resistance 2Ω each are connected in series.



Hence, their equivalent resistance = $(2+2) = 4\Omega$

Therefore, the circuit can be redrawn as

It can be observed that 2Ω and 4Ω resistors are connected in parallel in all the four loops.

Hence, equivalent resistance (R') of each loop is given by,

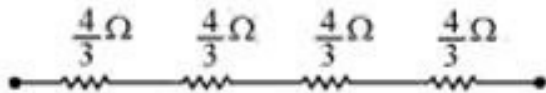

$$R' = \frac{2 \times 4}{2 + 4} = \frac{8}{6} = \frac{4}{3} \Omega$$

The circuit reduces to

All the four resistors are connected in series.

Hence, equivalent resistance of the given circuit is $\frac{4}{3} \times 4 = \frac{16}{3} \Omega$

(iii) It can be observed from the given circuit that five resistors of resistance R each are connected in series.

Hence, equivalent resistance of the circuit = $R + R + R + R + R = 5R$

8. Figure shows a potentiometer with a cell of 2.0 V and internal resistance 0.40Ω maintaining a potential drop across the resistor wire AB. A standard cell which



maintains a constant emf of 1.02 V (for very moderate currents up to a few mA) gives a balance point at 67.3 cm length of the wire. To ensure very low currents drawn from the standard cell, a very high resistance of 600 k Ω is put in series with it, which is shorted close to the balance point. The standard cell is then replaced by a cell of unknown emf and the balance point found similarly, turns out to be at 82.3 cm length of the wire.

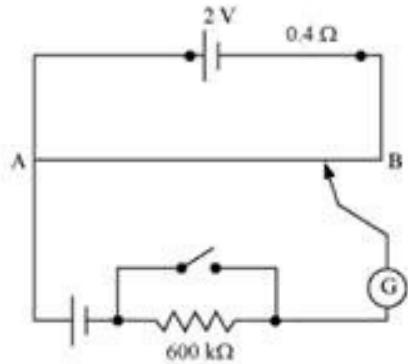

[a] What is the value \mathcal{E} ?

[b] What purpose does the high resistance of 600 k Ω have?

[c] Is the balance point affected by this high resistance?

[d] Is the balance point affected by the internal resistance of the driver cell?

[e] Would the method work in the above situation if the driver cell of the potentiometer had an emf of 1.0 V instead of 2.0 V?

[f] Would the circuit work well for determining an extremely small emf, say of the order of a few mV (such as the typical emf of a thermo-couple)? If not, how will you modify the circuit?

Ans. [a] Constant emf of the given standard cell, $E_1 = 1.02V$

Balance point on the wire, $l_1 = 67.3cm$

A cell of unknown emf, \mathcal{E} , replaced the standard cell. Therefore, new balance on the wire,

$l = 82.3cm$



The relation connecting emf and balance point is,

$$\frac{E_1}{l_1} = \frac{\varepsilon}{l}$$

$$\varepsilon = \frac{l}{l_1} \times E_1$$

$$= \frac{82.3}{67.3} \times 1.02 = 1.247V$$

The value of unknown emf is 1.247V.

[b] The purpose of using the high resistance of $600 \text{ k}\Omega$ is to reduce the current through the galvanometer when the movable contact is far from the balance point.

[c] The balance point is not affected by the presence of high resistance.

[d] The point is not affected by the internal resistance of the driver cell.

[e] The method would not work if the driver cell of the potentiometer had an emf of 1.0 V instead of 2.0 V. This is because if the emf of the driver cell of the potentiometer is less than the emf of the other cell, then there would be no balance point on the wire.

[f] The circuit would not work well for determining an extremely small emf. As the circuit would be unstable, the balance point would be close to end A. Hence, there would be a large percentage of error.

Modification: The given circuit can be modified if a series resistance is connected with the wire AB. The potential drop across AB is slightly greater than the emf measured. The percentage error would be small.



Bharat Board
Vedantu
The biggest community of X
LIVE ONLINE TRAINING

 **Thank You**
for downloading the PDF

FREE LIVE ONLINE

MASTER CLASSES

FREE Webinars by Expert Teachers



Vedantu

FREE MASTER CLASS SERIES

- ✓ For **Grades 6-12th** targeting **JEE, CBSE, ICSE** & much more
- ✓ **Free 60 Minutes Live Interactive** classes everyday
- ✓ Learn from the **Master Teachers** - India's best

Register for **FREE**

Limited Seats!